

MODEL : BBT 6913 A1 (W1400 x L1920mm) Bed ASSEMBLY INSTRUCTIONS

Read this instruction carefully. See hardware and furniture part list for guidance. Be sure all parts are complete, before you assemble. Place all wooden furniture parts on a clean and flat soft surface to prevent from being scratched. Follow the figure to start assembling.

CAUTIONS : 1. Do not FULLY - TIGHTEN the nut or nut bolt until all nut or bolt is ready assembled.
 2. Do not OVER - TIGHTEN the nut or bolt to avoid causing damages to the thread.
 3. Keep all hardware parts out of reach of children.

PART LIST		
ITEM	DESCRIPTION	QTY
A	HEADBOARD	1 PC
B	FOOTBOARD	1 PC
C	BED LEG	4 PCS
D	SIDE RAIL	2 PCS
E	CENTER RAIL	1 PC
F	CENTER SUPPORT LEG	3 PCS
G	BED SLAT	1 SET

HARDWARE LIST		
ITEM	DESCRIPTION	QTY
1	JCBB BOLT M8 x 20mm	16 PCS
2	M8 FLAT WASHER	16 PCS
3	M8 SPRING WASHER	16 PCS
4	WOOD SCREW M4 x 38mm	9 PCS
5	M5 ALLEN KEY (BALL SHAPE)	1 PC
6	VMB 3133	4 PCS

NOTE : THE LIST AND QUANTITY SHOWN ARE FOR 1 UNIT ASSEMBLY.
 Tool needed : Screwdriver (not provider).

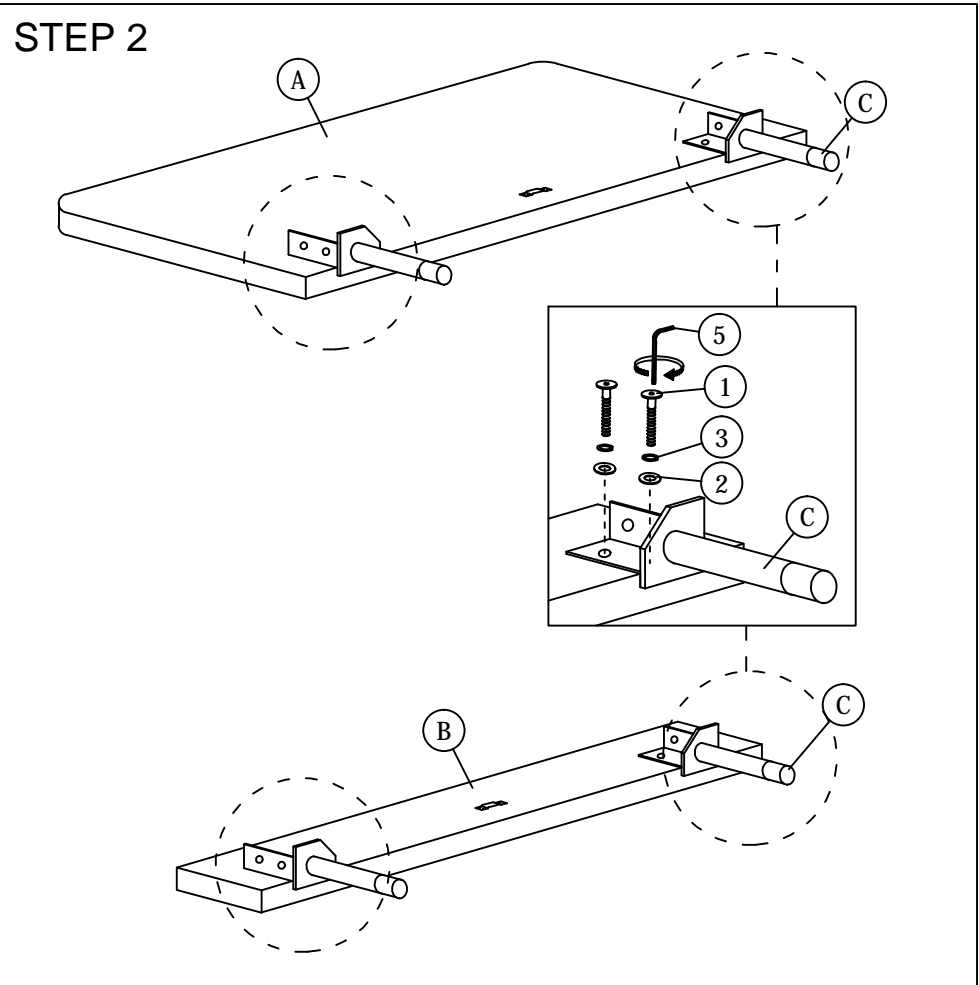
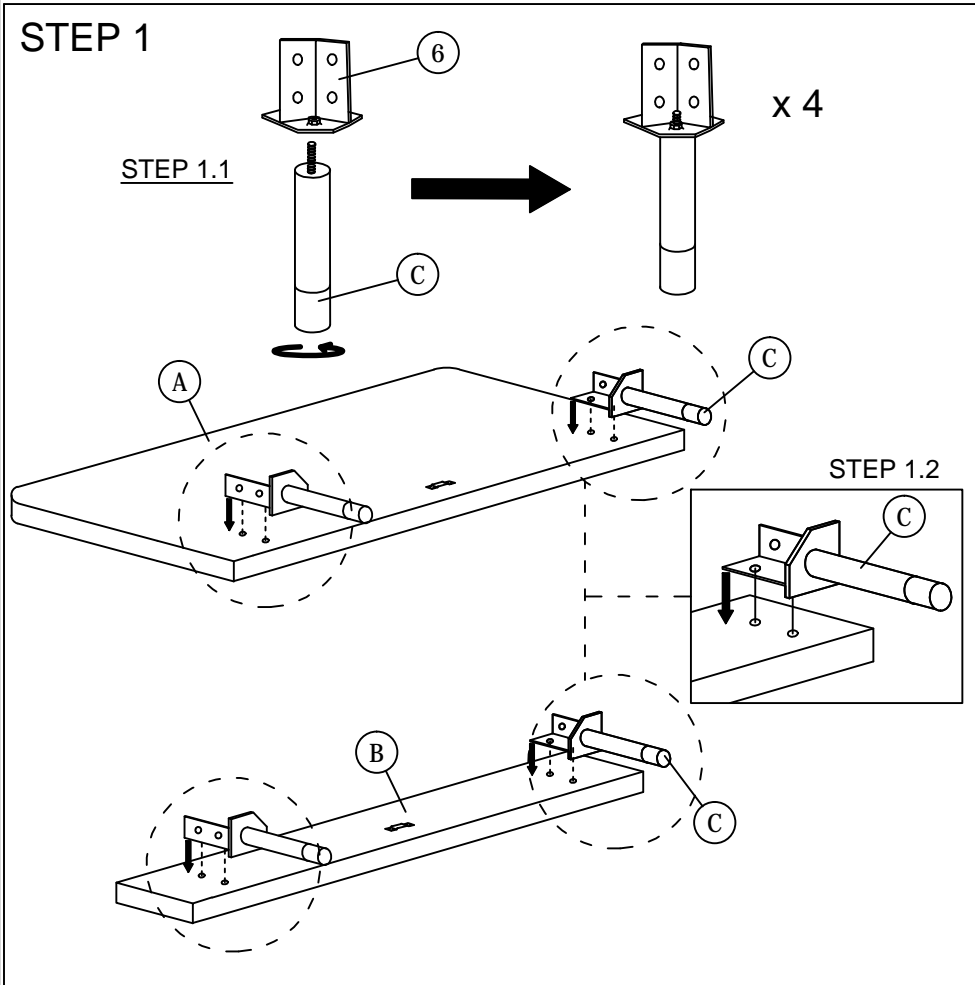

ASSEMBLY INSTRUCTIONS

STEP 3

STEP 3.1

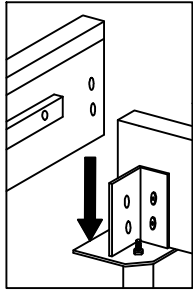

STEP 3.2

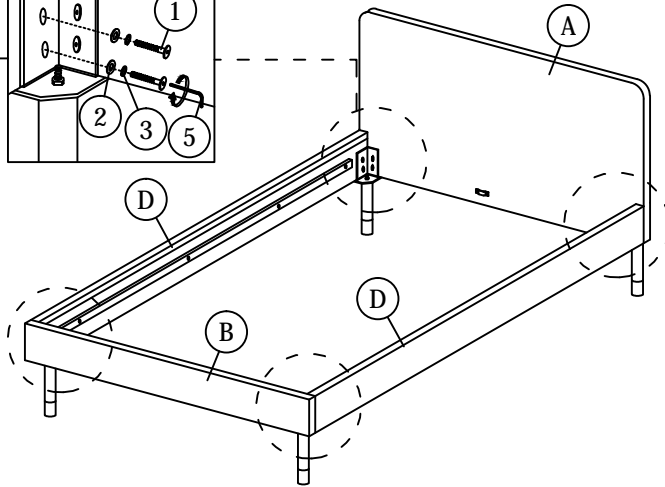
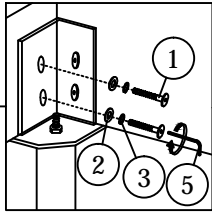

STEP 4

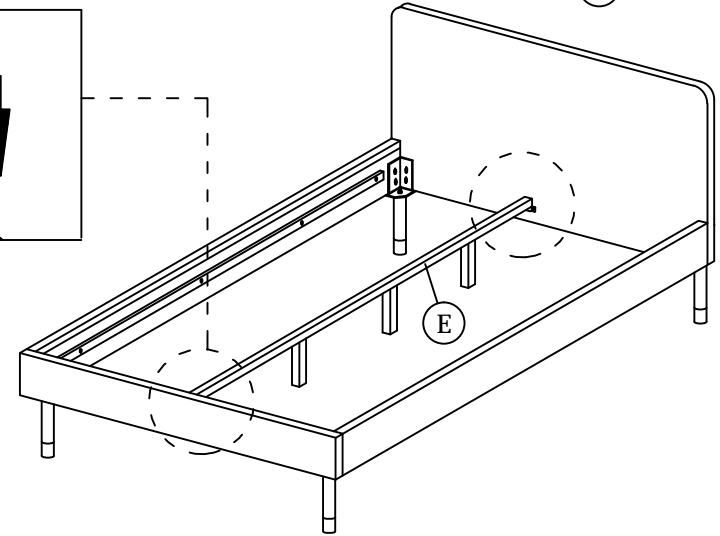
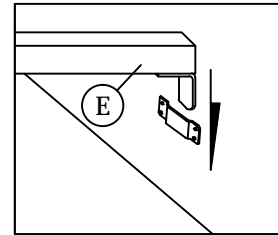
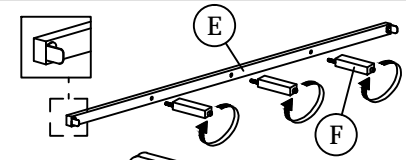

STEP 5

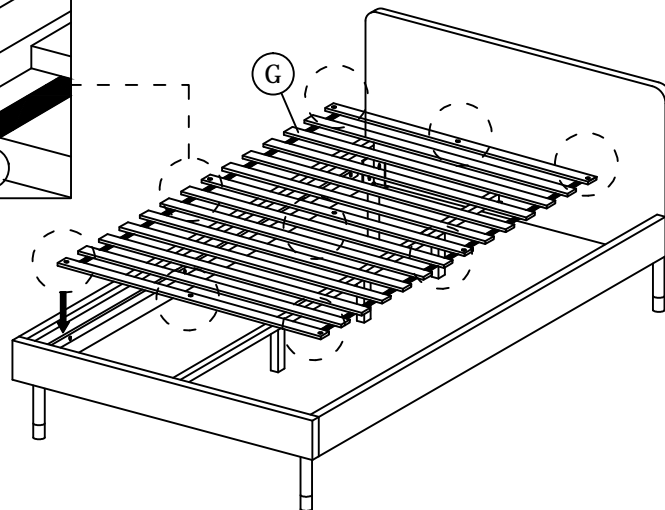
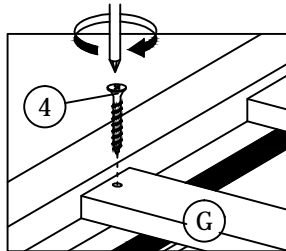

STEP 6

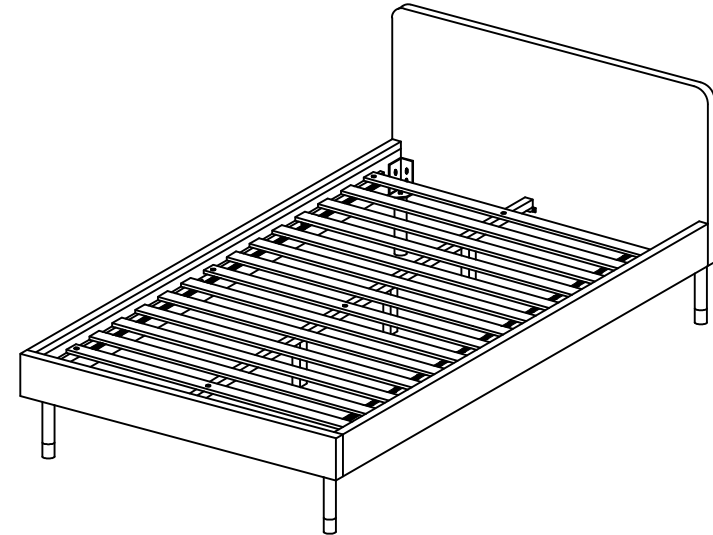

* When moving the bed position, the center support legs must be adjust to be straight to avoid any broken problem.